

Goodrive350 Series

High-performance Multi-function VFD



Goodrive350

Introduction	2
Product Advantages	3
Application Scenarios.....	12
Technical Specification	13
Type Selection.....	14
Installation Dimensions.....	16
Optional Parts	22



/ Introduction

GD350 is a brand new high-performance VFD which integrates the speed, torque, and position control. It is widely applicable to control over synchronous and asynchronous motors. It is highly extensible and flexible with PG card, PLC card, communication card and IO card, meeting the demands of various industries. It's oriented for mid&high end OEM market, mainly covering printing, packaging, winding, etc.



Features

- Support SVC and VC(Closed loop) control for both asynchronous and synchronous motors.
- Enable high precision of speed, position, torque control and fast speed response.
- Support Ethernet/IP, Profinet, CAN Master/Slave, etc.
- Accept plug-in of three expansion cards simultaneously (only two cards ≤ 5.5kW(10HP).
- Integrate safety function-STO(Safe Torque OFF, SIL2).
- Unique I/F control and online transition with other control modes are very suitable for the situation where the Asynchronous motor has low speed with high torque and the speed accuracy is not high.
- Multi-function LCD keypad.
- Support optional Bluetooth card and WIFI card.

Product Advantage

Full motion and all-round

Performance improvement

Compared with the products of last generation, the performance is significantly improved



Motor auto-tuning

- Asynchronous motor--Eliminates the impact of the skin effect, improving the auto-tuning precision.
- Synchronous motor--Performs auto-tuning on the counter-electromotive force, effectively avoids the impact of the initial value of the counter-electromotive force.

DC braking

- The current change is smoother in the process of the motor entering DC braking from rotating, the current shock is weak, and the current response is faster.

Rotating speed tracking

- In any of the control modes, the rotating speed tracking method brings the least current shock, and thus significantly improves the stability.

High torque at low speed

- Special I/F control, featuring constant current source, highly applicable to scenarios where multiple motors are to be driven simultaneously and high torque is required at low speed.

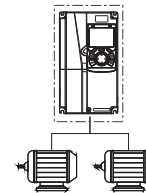

State	IO/IN(M)(%)	
	Multi-pointVF	I/F control
Before and after brake open in forward running	62.80%	133.40%
Before and after brake open in reverse running	62.50%	130.30%
Before and after brake close in forward running	65.70%	136.10%
Before and after brake close in reverse running	92.00%	136.30%

Data measured on a construction machinery site

Control performance

- New-type flux linkage observer, improving the stability of the high-speed control.
- New-type speed/current regulator, improving the current control result in quick start and reducing speed overshoot.
- New-type phase-locked loop, improving the stability of high-torque control.
- Compensation for output voltage phases and amplitude, improving the stability of high- and low-speed carriers.
- Adding the synchronous motor VF control mode based on reactive current control. The output current adapts to the load and the oscillation suppression algorithm.

Drive multiple motors

Applicable to drive various motors

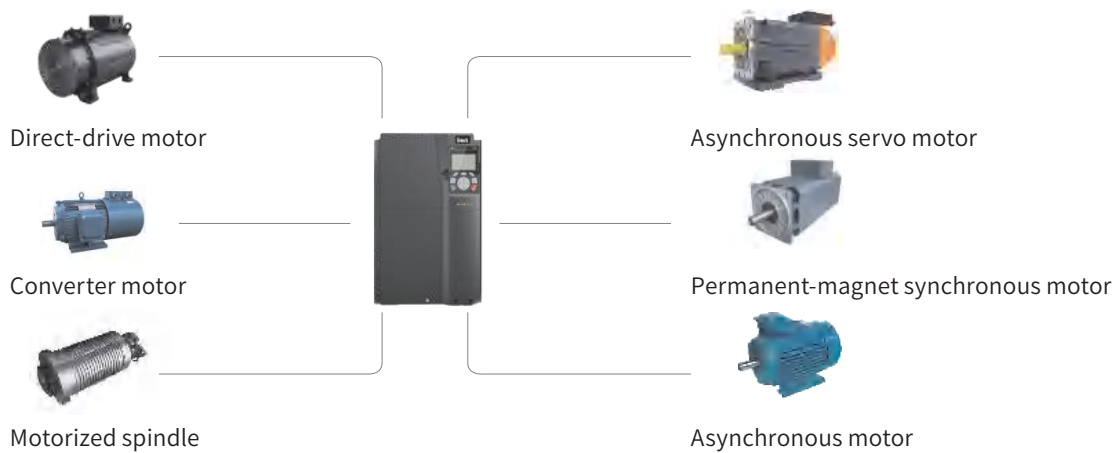

Combine different controls

More precise, stronger torque, speed, and position control over motors

Characteristic indicator	Goodrive350
Position control precision	±1pulse

(2) Torque and speed control performance--Ensure stable mechanical operation, fast response, and low torque ripple

Characteristic indicator	Goodrive350
Speed regulation range	1:1000
Speed stabilization precision	+0.02%
Response time in torque control	<10ms
Torque control precision	5%
Start frequency/higher start torque	0Hz/200%

Keep running when power down

When the grid encounters a momentary power outage, the VFD can keep running by using the fed-back energy within a certain period of time.

It is highly applicable to chemical fiber and textile production lines and other scenarios where the device is Required to run continuously.

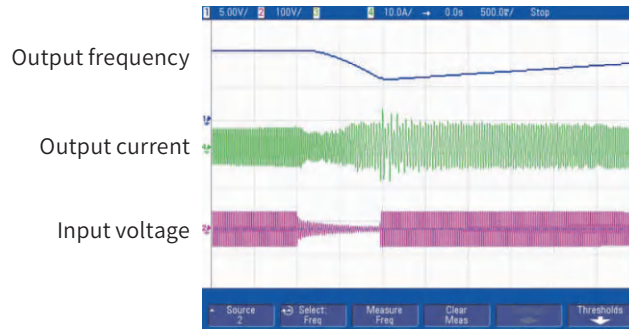

Multiple braking modes to enable fast stop

Dynamic braking	DC braking	Magnetic braking	Short-circuit braking
High torque fast speed	No brake unit or brake resistor required	No brake unit or brake resistor required; allowing fast braking	No brake unit or brake resistor required; allowing fast braking
Large-inertia loads scenarios are frequently braked	Applicable to scenarios where freely running motors are to be braked first and then started and where torque output needs to be kept after the motor is braked to run at the speed of zero	Applicable to scenarios where large inertia loads are to be fast stopped at low frequency	Applicable only to fast stop of PMSMs or braking and then starting freely running PMSMs

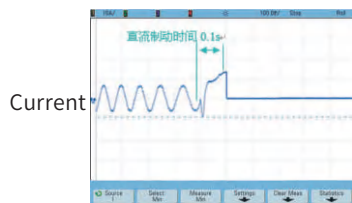

Current wave in the SVPWM mode for asynchronous motors
Frequency: 10Hz
Braking current: 100%

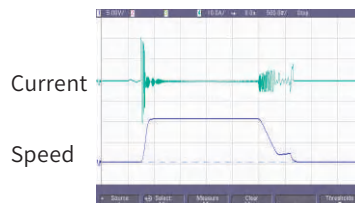

PMSM short-circuit braking wave
Acceleration time: 0.1s
Deceleration time is 0.4s

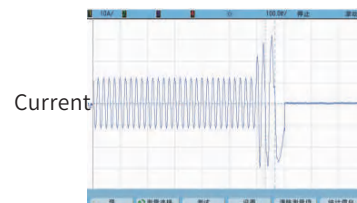

Magnetic flux braking current wave in the SVPWM mode for asynchronous motors
Frequency: 50Hz
Rated load: 100%

Proper voltage and current control, effectively reducing the number of VFD fault protection times

Overvoltage stal	Overcurrent stal
Regulates the output frequency during deceleration to prevent the motor from generating too much power due to too fast deceleration	Regulates the output frequency during acceleration to prevent too heavy loads caused due to too fast acceleration

Excellent driving performance on special motors

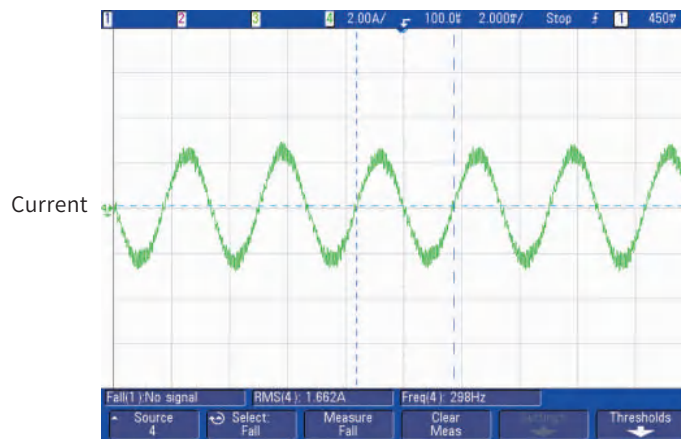

Current wave at 300 Hz with 100% of the rated load in the open-loop vector control mode for synchronous motors

Multi-function

Enhanced extension performance

- (1) Optional PLC, I/O, communication, and PG cards
- (2) Consistent extension card dimensions

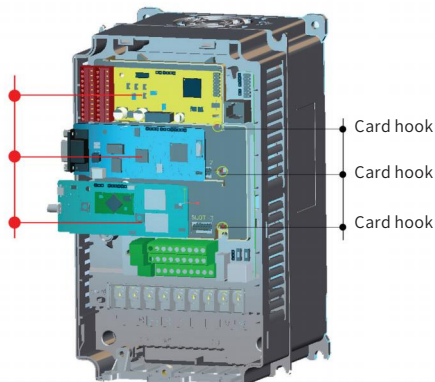

≥7.5kW

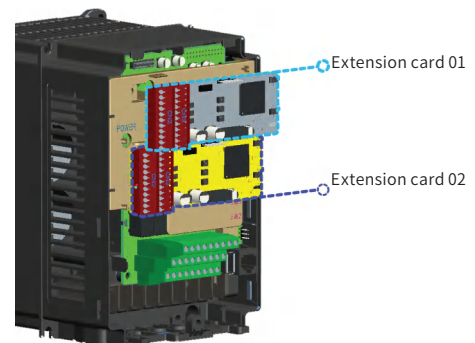

≤5.5kW

Supporting customers' secondary development

- (1) Meeting customization requirements, reducing customers' costs, and improving the processes
- (2) Optional PLC card, 128 k program memory space

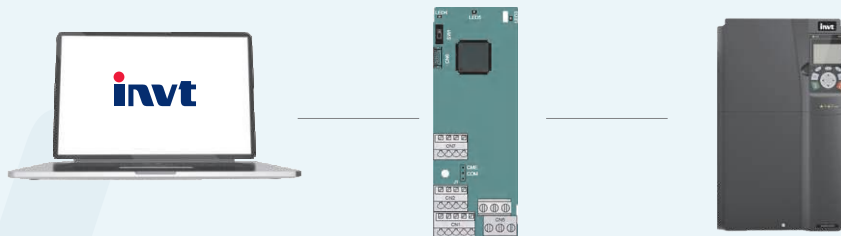

Supporting various industrial communication protocols

- (1) Standard Modbus communication, supporting the following communication modes based on extension cards

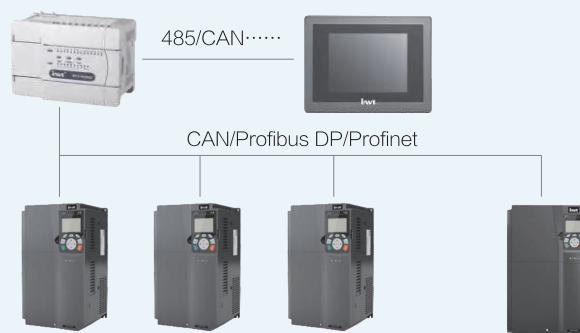

Adopting the digital filtering technology that improves EMC; the anti-interference performance is twice that of conventional solutions

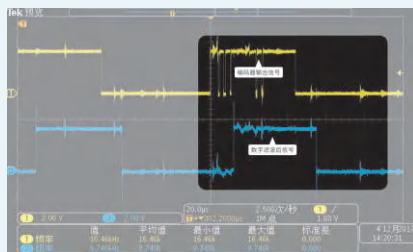

- (1) Supporting pulse reference and frequency-divided output;
- (2) providing the fast encoder disconnection detection function to prevent the expansion of the system fault impact

Encoder signal: near-field coupling of 100m motor wire

Standard two HDIs that can serve as speed sources or high-speed AB pulse inputs, which can be used for simple closed-loop application



Supporting built-in brake units at a maximum of 110 kW, reducing customers' costs and installation space

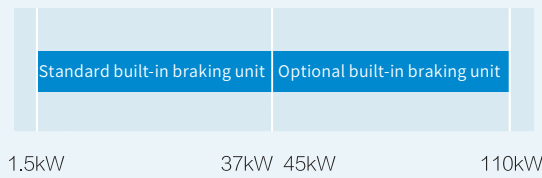

Providing built-in DC reactors for models of 18.5 kW–110 kW

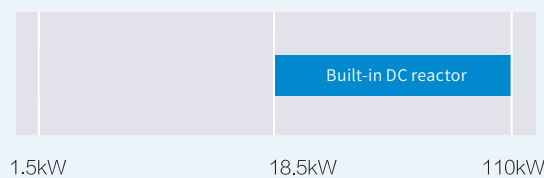

Built-in C3 input filters; optional C2 filters for 380V models

Built-in C3 input filters of 380 V in factory reduce external installation space and prevents electromagnetic interference

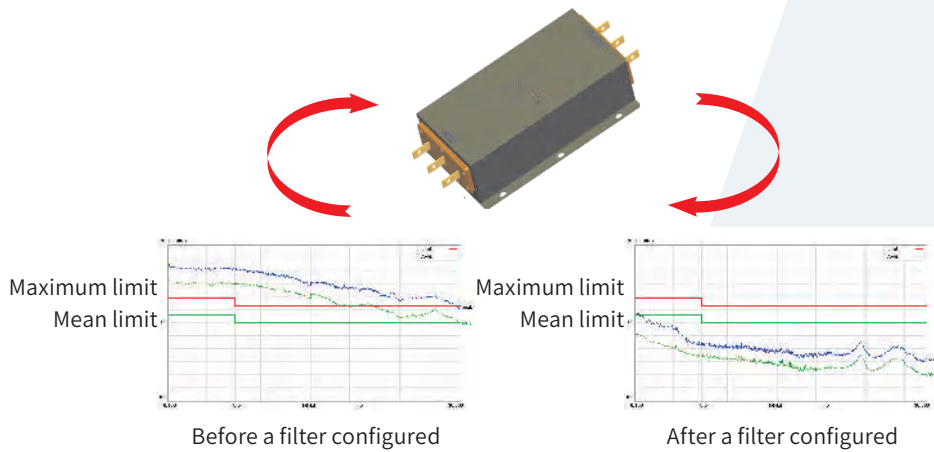

Test for power terminal conduct disturbance

Note:

C2 filters: EMC performance meets civilian environments.
 C3 filters: EMC performance meets industrial environments.

Abundant external interfaces, meeting the requirements of most application sites

Terminal type	Quantity	Feature
Digital input	4	1. Programmable multi function terminal 2. Max. input frequency: 1 kHz 3. Compatible with both NPN and PNP inputs
High-speed pulse input	2	1. Max. input frequency: 50 kHz 2. Compatible with both NPN and PNP inputs 3. Supporting the input of quadrature encoders, and provide the speed detection function
Analog input	2	0~10V, 0~20mA, -10~10V
Digital output	1	Max. output frequency: 1 kHz
High-speed pulse output	1	Max. output frequency 50kHz
Analog output	2	0~10V, 0~20mA
Relay output	2	3A/AC250V, 1A/DC30V; NO+NC

Ease of use

Wireless commissioning

(1) Bluetooth/WIFI connection. You can use the mobile phone application to substitute for the traditional keypad.

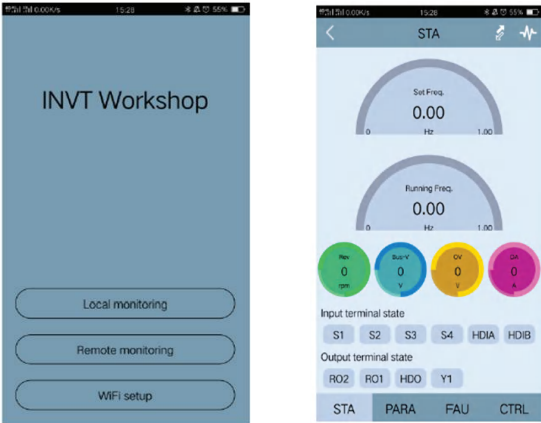

Connecting through the Internet of Things (IoT), remote monitoring

(1) Wireless access. You can easily connect to the IoT, operate the VFD through mobile phone or PC, and obtain the running state of the VFD in real time.

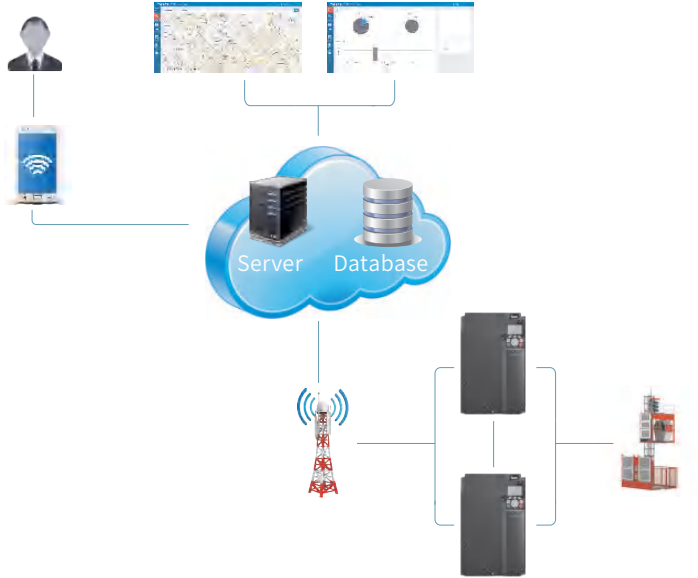

Standard USB interface

USB update

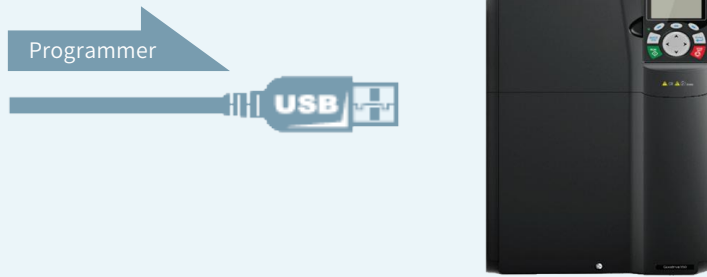

Providing the multi-function LCD operating panel, user-friendly design, focusing on user experience

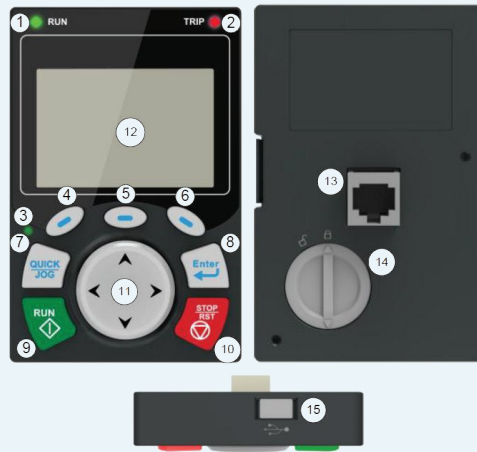

No.	name	No.	name
1	Run	9	Running key
2	Trip	10	Stop/Reset key
3	Quick/Jog	11	Direction key
4	Function key	12	Display screen
5		13	RJ45 interface
6		14	Clock battery cover
7	Shortcut key	15	MiniUSB terminal
8	Confirmation key		

Safe and reliable

Optimal reliability test system, ensuring that the product meets the most complicated application environments

INVT is the first manufacturer in China that has been awarded the Acceptance of Client Testing (ACT) accreditation (data accreditation) issued by TÜV SÜD, which means the technologies, test data, and test reports of INVT's labs are accepted by TÜV SÜD.

Providing the built-in safe torque off (STO) function, reaching the international level, ensuring more safe and reliable application

- (1) SIL2 level
- (2) Can be used to set up a safety system

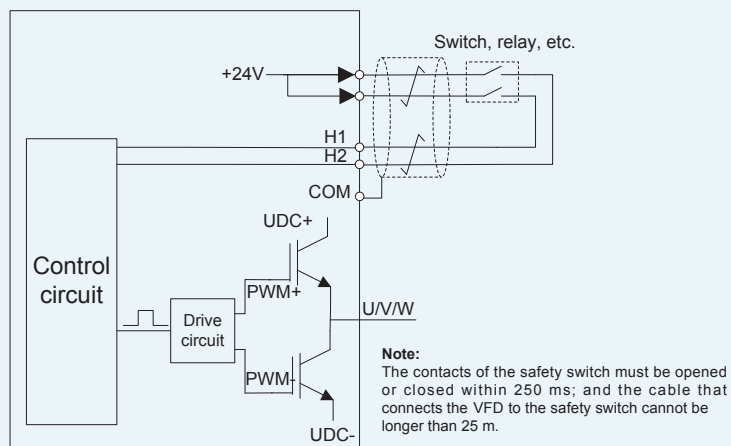

/ Application Scenarios

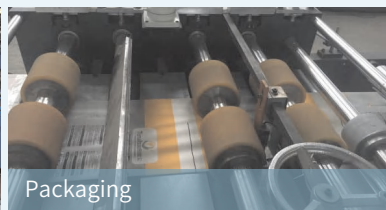

Technical Specification

Function description		Specification
Power input	Input voltage (V)	AC 3PH 380V (-15%)–440V (+10%) rated voltage: 380V AC 3PH 520V (-15%)–690V (+10%) rated voltage: 660V
	Input current (A)	Refer to Rated value
	Input frequency (Hz)	50Hz or 60Hz, allowable range: 47–63Hz
Power output	Output voltage (V)	0–input voltage
	Output current (A)	Refer to Rated value
	Output power (kW)	Refer to Rated value
	Output frequency (Hz)	0–400Hz
Technical Control performance	Control mode	SVPWM control, SVC, VC
	Motor type	Asynchronous motor, permanent magnet synchronous motor
	Speed regulation ratio	Asynchronous motor 1: 200 (SVC); Synchronous motor 1 20 (SVC) , 1:1000 (VC)
	Speed control precision	±0.2% (SVC), ±0.02% (VC)
	Speed fluctuation	± 0.3% (SVC)
	Torque response	<20ms SVC) , <10ms (VC)
	Torque control precision	10% (SVC) , 5% (VC)
	Starting torque	Asynchronous motor: 0.25Hz/150% (SVC) Synchronous motor: 2.5 Hz/150% (SVC) 0Hz/200% (VC)
	Overload capacity	150% of rated current: 1min; 180% of rated current: 10s; 200% of rated current: 1s;
Running control performance	Frequency setup mode	Digital, analog, pulse frequency, multi -step speed Provide over 30 kinds of fault protection functions: overcurrent, overvoltage, undervoltage, overtemperature, phase loss and overload, etc
	Automatic voltage regulation function	Keep the output voltage constant when grid voltage changes.
	Fault protection function	Fault protection function Provide over 30 kinds of fault protection functions: overcurrent, overvoltage, under-voltage, over-temperature, phase loss and overload, etc.
	Speed tracking restart function	Realize impact-free starting of the motor in rotating Note: This function is available for 4kW and above models
Peripheral Interface	Terminal analog input	No more than 20mV
	Terminal digital input resolution	No more than 2ms
	Analog input	2 inputs, AI1: 0–10V/0–20mA; AI2: -10–10V
	Analog output	1 output, AO1: 0–10V /0–20mA
	Digital input	Four regular inputs; Max. frequency: 1kHz; Internal impedance: 3.3kΩ Two high-speed inputs; Max. frequency: 50kHz; supports quadrature encoder input; Speed measurement function
	Digital output	One high-speed pulse output; max. frequency: 50kHz One Y terminal open collector output
	Relay output	Two programmable relay outputs RO1A NO, RO1B NC, RO1C common port RO2A NO, RO2B NC, RO2C common port Contact capacity: 3A/AC250V, 1A/DC30V
	Extension interface	Three extension interfaces: SLOT1, SLOT2, SLOT3 Expandable PG card, programmable extension card, communication card, I/O card, etc.

Function description		Specification
Others	Installation mode	Support wall -mounting, floor-mounting and flange mounting
	Temperature of running environment	-10~50°C, derating is required if the ambient temperature exceeds 40°C
	Protection level	IP20
	Pollution level	Level 2
	Cooling mode	Air cooling
	Brake unit	Built- in brake unit for 380V 37kW and below models; Optional built-in brake unit for 380V 45kW~110kW(inclusive) models; Optional external brake unit for 660V models;
	EMC filter	380V models fulfill the requirements of IEC61800-3 C3 Optional external filter should meet the requirements of IEC61800-3 C2

/ Type Selection

GD350 – 5R5G – 4 – B

① ② ③ ④

Fig 3.6 Type designation key

Sign	Description	Contents
①	Abbreviation of series	GD350: Goodrive350 high-performance multi-function VFD
②	Power range + load type	5R5-5.5kW G— Constant torque load
③	Voltage level	4: AC 3PH 380V (-15%)~440V (+10%) Rated voltage: 380V 6: AC 3PH 520V (-15%)~690V (+10%) Rated voltage: 660V
④	Brake unit	B:Optional built-in braking unit

Note: For details about the selection of ip55 products, please refer to the GD350-IP55 Chinese manual

Power ratings and dimension

VFD model	Rated output power (kW)	Input current (A)	Rated output current (A)	Net/Gross weight (kg)	Dimension (mm)
AC 3PH 380V(-15%)~440V(+10%)					
GD350-1R5G-4	1.5	5.0	3.7	2/3	126*186*185
GD350-2R2G-4	2.2	5.8	5		
GD350-004G-4	4	13.5	9.5	2.5/3.5	126*186*201
GD350-5R5G-4	5.5	19.5	14		
GD350-7R5G-4	7.5	25	18.5	3/4	146*256*192
GD350-011G-4	11	32	25	6/7	170*320*220
GD350-015G-4	15	40	32		

VFD model	Rated output power (kW)	Input current (A)	Rated output current (A)	Net/Gross weight (kg)	Dimension (mm)
AC 3PH 380V(-15%)~440V(+10%)					
GD350-018G-4	18.5	47	38	8.5/10.5	200*340.6*208
GD350-022G-4	22	51	45		
GD350-030G-4	30	70	60	16/17	250*400*223
GD350-037G-4	37	80	75		
GD350-045G-4	45	98	92	25/29	282*560*258
GD350-055G-4	55	128	115		
GD350-075G-4	75	139	150		
GD350-090G-4	90	168	180	41/52	338*554*330
GD350-110G-4	110	201	215		
GD350-132G-4	132	265	260	85/110	500*870*360
GD350-160G-4	160	310	305		
GD350-185G-4	185	345	340		
GD350-200G-4	200	385	380		
GD350-220G-4	220	430	425	135/165	680*960*380
GD350-250G-4	250	460	480		
GD350-280G-4	280	500	530		
GD350-315G-4	315	580	600		
GD350-355G-4	355	625	650	350/407	620*1700*560
GD350-400G-4	400	715	720		
GD350-500G-4	500	890	860		
AC 3PH 520V(-15%)~690V(+10%)					
GD350-022G-6	22	35	27	30/32	270*555*325
GD350-030G-6	30	40	34		
GD350-370G-6	37	47	42		
GD350-045G-6	45	52	54	47/67	325*680*365
GD350-055G-6	55	65	62		
GD350-075G-6	75	85	86		
GD350-090G-6	90	95	95		
GD350-110G-6	110	118	131	85/110	500*870*360
GD350-132G-6	132	145	147		
GD350-160G-6	160	165	163		
GD350-185G-6	185	190	198	135/165	680*960*380
GD350-200G-6	200	210	216		
GD350-220G-6	220	230	240		
GD350-250G-6	250	255	274		
GD350-280G-6	280	286	300		
GD350-315G-6	315	334	328		
GD350-355G-6	355	360	380		

GD350-400G-6	400	411	426	350/407	620*1700*560
GD350-450G-6	450	445	465		
GD350-500G-6	500	518	540		
GD350-560G-6	560	578	600		
GD350-630G-6	630	655	688		

/ Installation Dimension

Wall mounting installation diagram

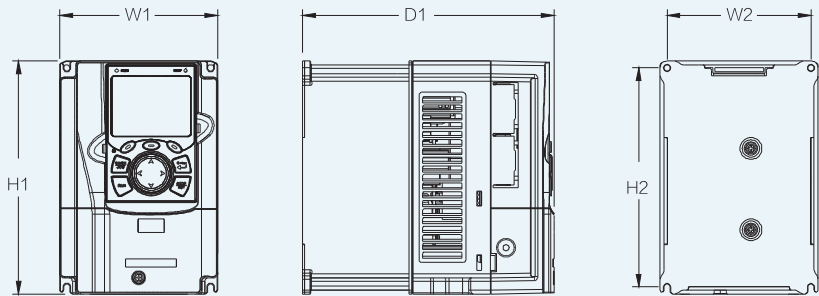

380V, 1.5~37kW

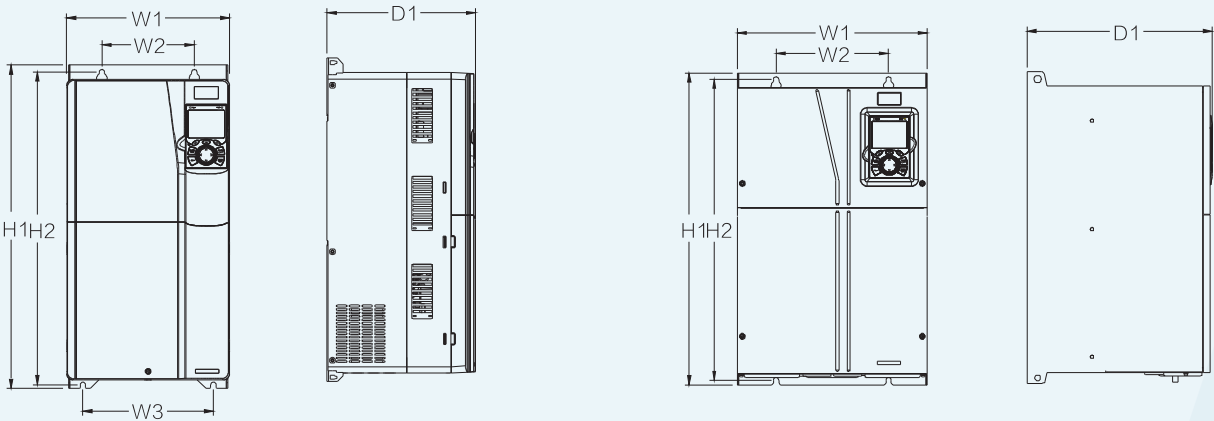

380V, 45~75kW

380V, 90~110kW

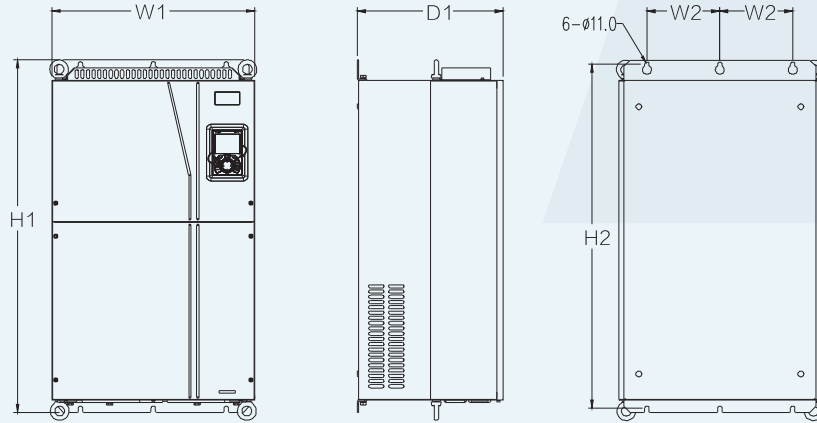

660V, 160~220kW

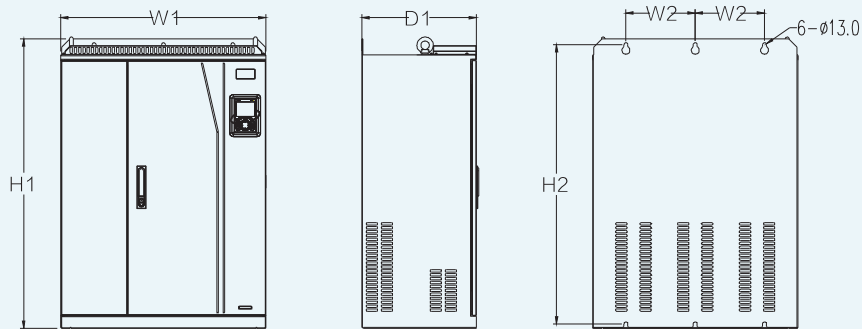

660V, 250~355kW

Model		W1	W2	W3	H1	H2	D1	Installation hole diameter	Fixing screw
380	1.5kW~2.2kW	126	115	-	186	175	185	5	M4
	4kW~5.5kW	126	115	-	186	175	201	5	M4
	7.5kW	146	131	-	256	243.5	192	6	M5
	11kW~15kW	170	151	-	320	303.5	220	6	M5
	18.5kW~22kW	200	185	-	340.6	328.6	208	6	M5
	30kW~37kW	250	230	-	400	380	223	6	M5
	45kW~75kW	282	160	226	560	542	258	9	M8
	90kW~110kW	338	200	-	554	535	330	10	M8
	132kW~200kW	500	180	-	870	850	360	11	M10
	220kW~315kW	680	230	-	960	926	380	13	M12
660V	22kW~45kW	270	130	-	555	540	325	7	M6
	55kW~132kW	325	200	-	680	661	365	9.5	M8
	160kW~220kW	500	180	-	870	850	360	11	M10
	250kW~355kW	680	230	-	960	926	380	13	M12

Flange mounting installation diagram

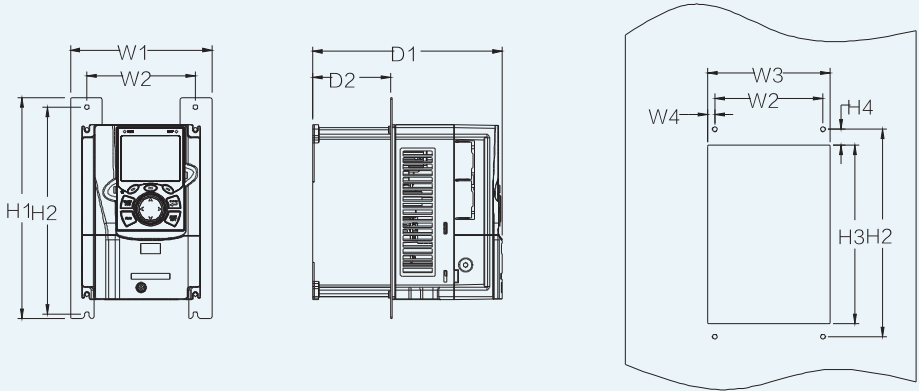

380V, 1.5~75kW

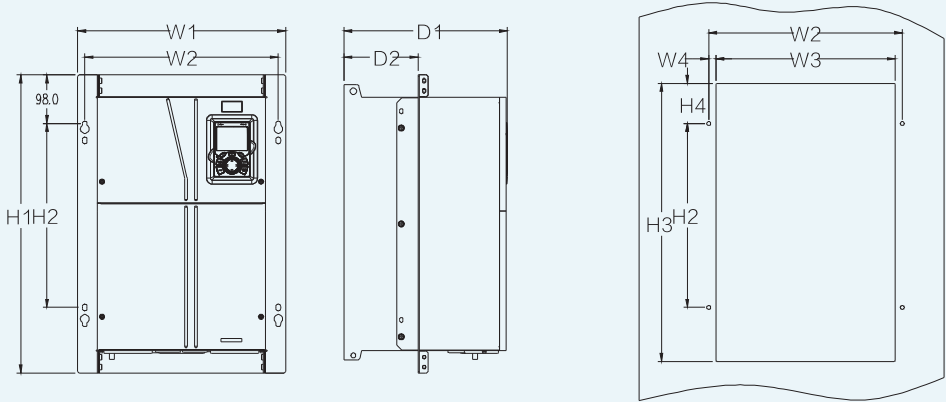

380V, 90~110kW

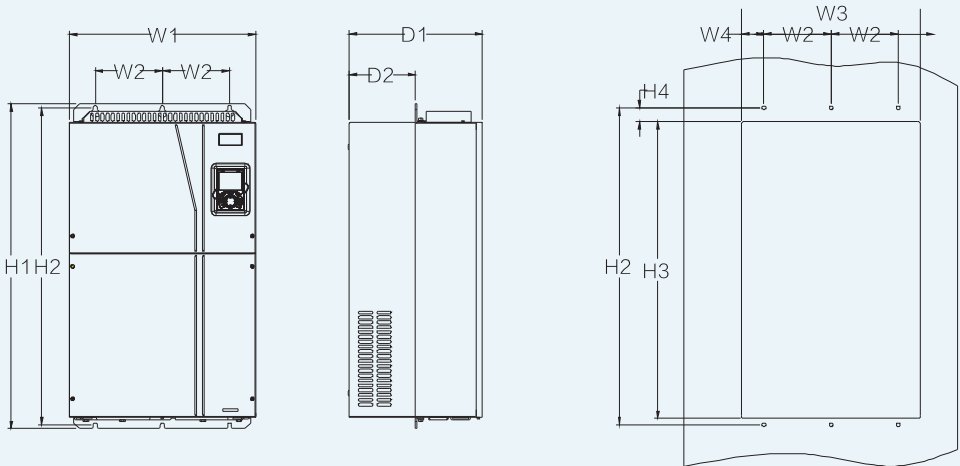

380V, 132~220kW

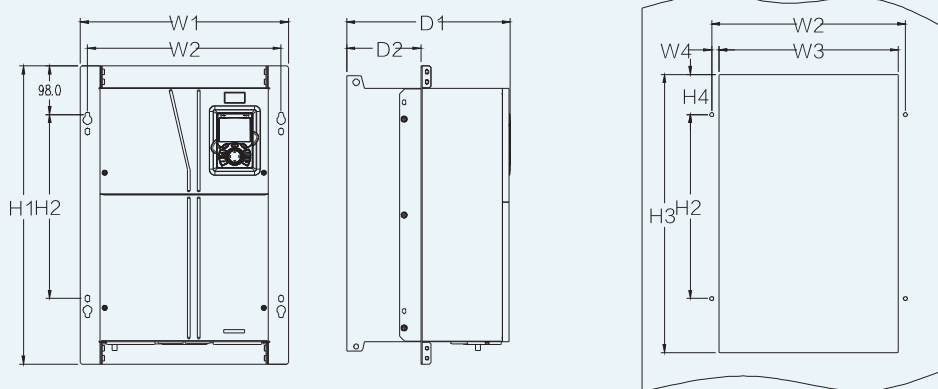

660V, 22~132kW

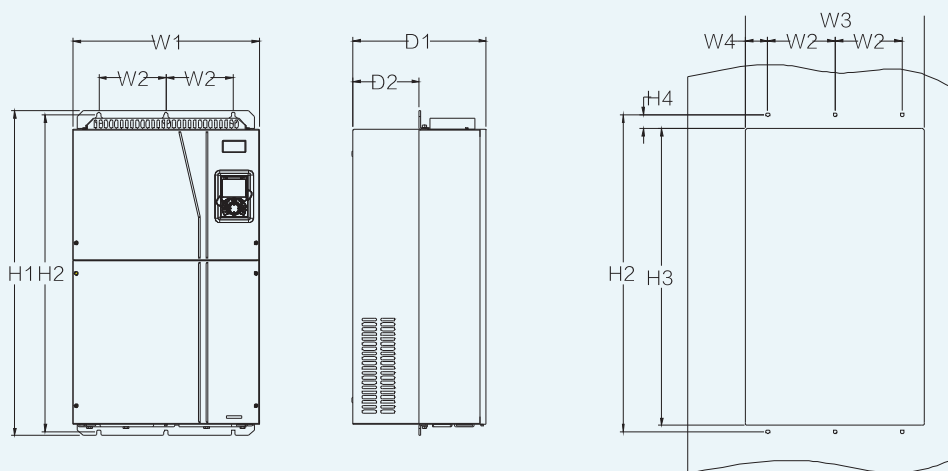

600V, 160~220kW

Model		W1	W2	W3	W4	H1	H2	H3	H4	D1	D2	Installation hole diameter	Fixing screw
380V	1.5kW~2.2kW	150.2	115	130	7.5	234	220	190	13.5	185	65.5	5	M4
	4kW~5.5kW	150.2	115	130	7.5	234	220	190	13.5	201	83	5	M4
	7.5kW	170.2	131	150	9.5	292	276	260	6	192	84.5	6	M5
	11kW~15kW	191.2	151	174	11.5	370	351	324	12	220	113	6	M5
	18.5kW~22kW	266	250	224	13	371	250	350.6	20.3	208	104	6	M5
	30kW~37kW	316	300	274	13	430	300	410	55	223	118.3	6	M5
	45kW~75kW	352	332	306	12	580	400	570	80	258	133.8	9	M8
	90kW~110kW	418.5	389.5	361	14.2	600	370	559	108.5	330	149.5	10	M8
	132kW~200kW	500	180	480	60	870	850	796	37	360	178.5	11	M10
660V	22kW~45kW	270	130	261	65.5	555	540	56	17	325	167	7	M6
	55kW~132kW	325	200	317	58.5	680	661	626	23	363	182	9.5	M8
	160kW~220kW	500	180	480	60	870	850	796	37	358	178.5	11	M10

Floor mounting installation diagram

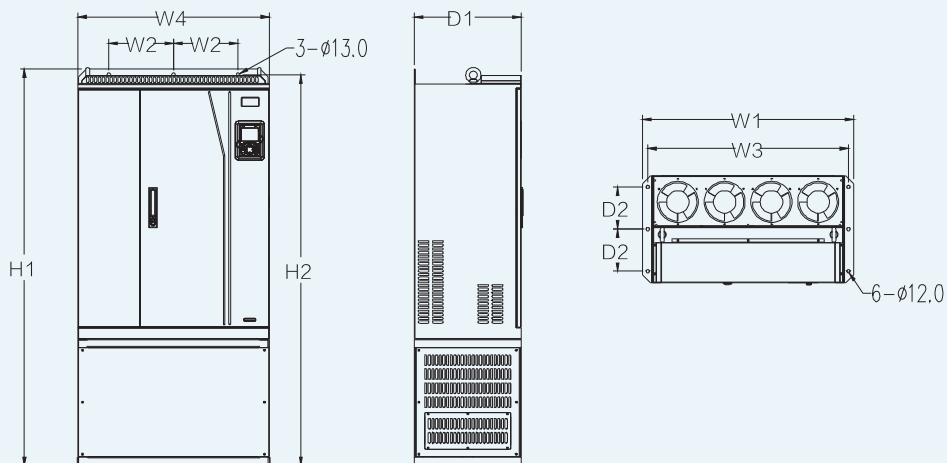

380V, 220~315kW

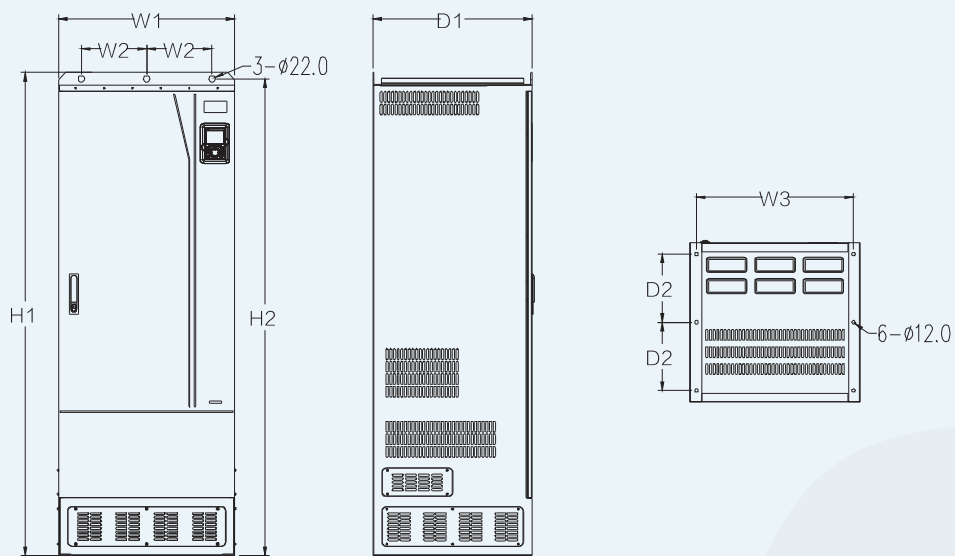

380V, 355~500kW

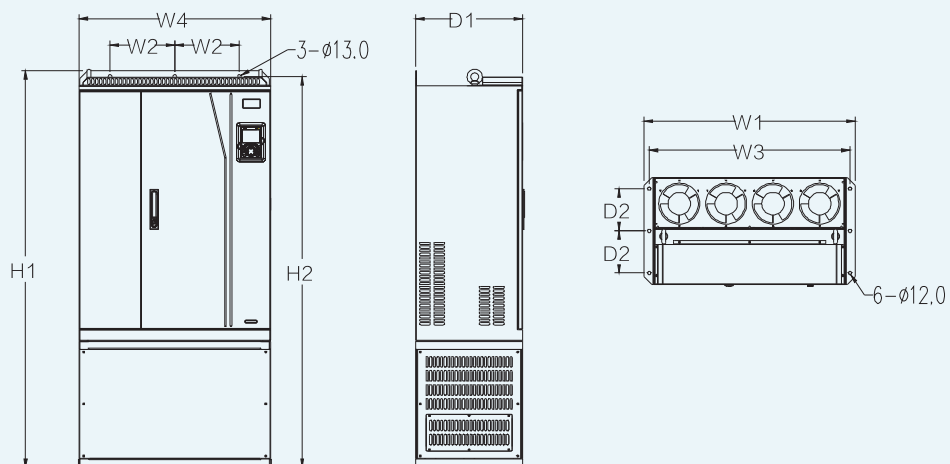

660V, 250~355kW

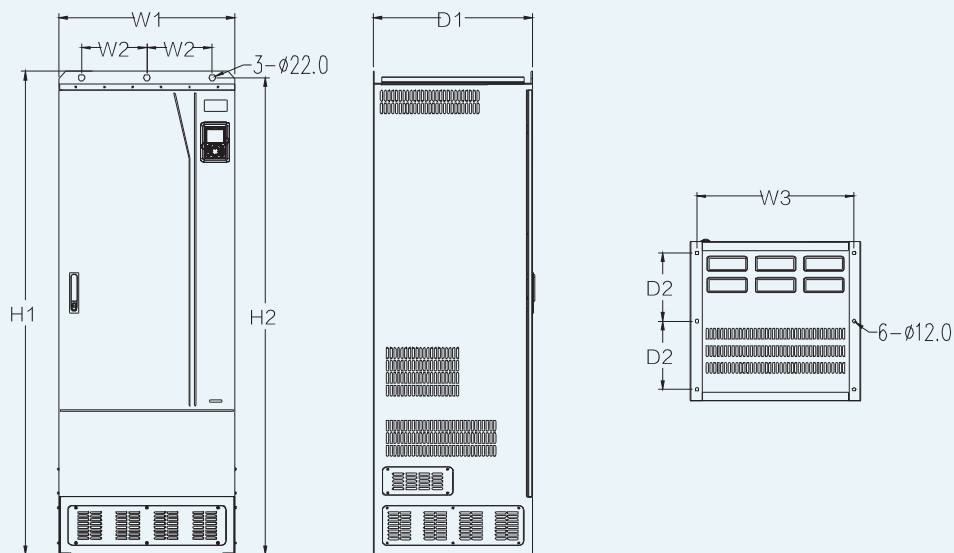

660V, 400~630kW

Model		W1	W2	W3	W4	H1	H2	D1	D2	Installation hole diameter	Fixing screw
380V	220kW~315kW	750	230	714	680	1410	1390	380	150	13\12	M12/M10
	355kW~500kW	620	230	572	-	1700	1678	560	240	22\12	M20/M10
660V	250kW~355kW	750	230	714	680	1410	1390	380	150	13\12	M12/M10
	400kW~630kW	620	230	572	\	1700	1678	560	240	22\12	M20/M10

/ Optional Parts

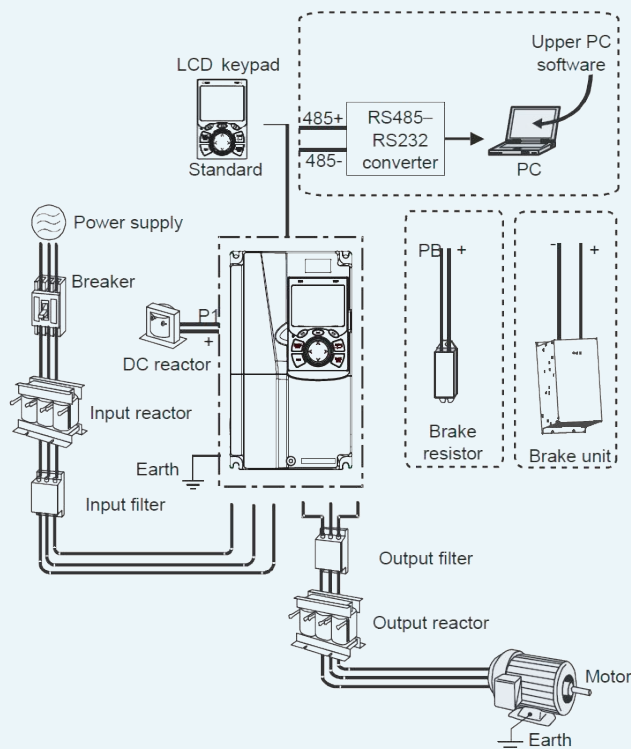

- VFDs of 380V, 37 kW or lower are equipped with built-in brake units, and VFDs of 45 kW to 110 kW can be configured with optional built-in brake units
- VFDs of 380 V, 18.5 kW to 110 kW are equipped with built-in DC reactors
- P1 terminals are equipped only for VFDs of 380 V, 132 kW or higher, which enable the VFDs to be directly connected to external DC reactors
- P1 terminals are equipped for all VFDs of the 660 V series or higher, which enable the VFDs to be directly connected to external DC reactors
- The brake units INVT's DBU series standard brake units. For details, see the DBU operation manual

Breakers and electromagnetic contactors

	Model	Fuse (A)	Breaker (A)	Rated current of the contactor (A)
380V	GD350-1R5G-4	1	16	10
	GD350-2R2G-4	17.4	16	10
	GD350-004G-4	30	25	16
	GD350-5R5G-4	45	25	16
	GD350-7R5G-4	60	40	25
	GD350-011G-4	78	63	32
	GD350-015G-4	105	63	50
	GD350-018G-4	114	100	63

	Model	Fuse (A)	Breaker (A)	Rated current of the contactor (A)
380V	GD350-022G-4	138	100	80
	GD350-030G-4	186	125	95
	GD350-037G-4	228	160	120
	GD350-045G-4	270	200	135
	GD350-055G-4	315	200	170
	GD350-075G-4	420	250	230
	GD350-090G-4	480	315	280
	GD350-110G-4	630	400	315
	GD350-132G-4	720	400	380
	GD350-160G-4	870	630	450
	GD350-185G-4	1110	630	580
	GD350-200G-4	1110	630	580
	GD350-220G-4	1230	800	630
	GD350-250G-4	1380	800	700
	GD350-280G-4	1500	1000	780
	GD350-315G-4	1740	1200	900
	GD350-355G-4	1860	1280	960
	GD350-400G-4	2010	1380	1035
	GD350-450G-4	2445	1630	1222
	GD350-500G-4	2505	1720	1290
660V	GD350-022G-6	105	63	50
	GD350-030G-6	105	63	50
	GD350-370G-6	114	100	63
	GD350-045G-6	138	100	80
	GD350-055G-6	186	125	95
	GD350-075G-6	270	200	135
	GD350-090G-6	270	200	135
	GD350-110G-6	315	200	170
	GD350-132G-6	420	250	230
	GD350-160G-6	480	315	280
	GD350-185G-6	480	315	280
	GD350-200G-6	630	400	315
	GD350-220G-6	720	400	380
	GD350-250G-6	720	400	380
	GD350-280G-6	870	630	450
	GD350-315G-6	1110	630	580
GD350-355G-6	1110	630	580	

Model		Fuse (A)	Breaker (A)	Rated current of the contactor (A)
660V	GD350-400G-6	1230	800	630
	GD350-450G-6	1470	960	735
	GD350-500G-6	1500	100	780
	GD350-560G-6	1740	1200	900
	GD350-630G-6	2010	1380	1035

Reactors

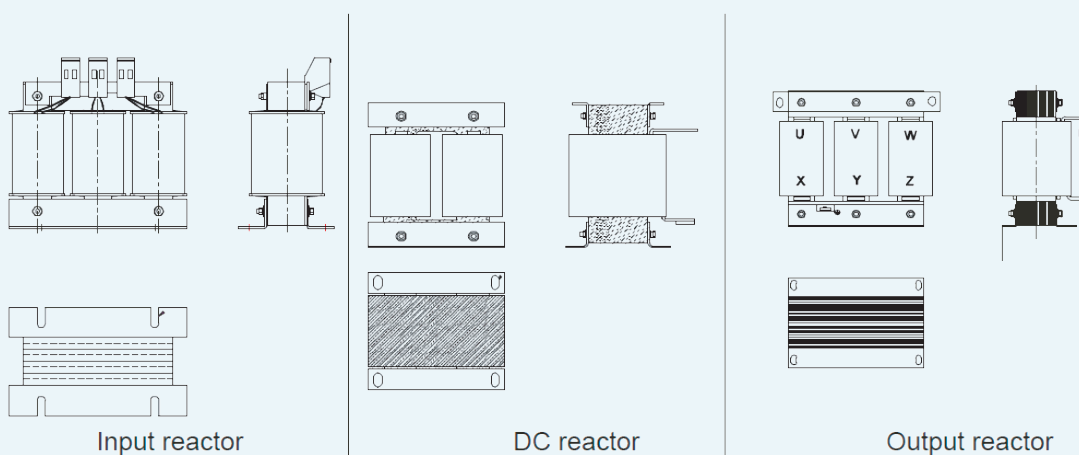

Model	Input reactor	DC reactor	Output reactor	
380V	GD350-1R5G-4	GDL-ACL0005-4CU	GDL-OCL0005-4CU	
	GD350-2R2G-4	GDL-ACL0006-4CU	GDL-OCL0006-4CU	
	GD350-004G-4	GDL-ACL0014-4CU	GDL-OCL0010-4CU	
	GD350-5R5G-4	GDL-ACL0020-4CU	GDL-OCL0014-4CU	
	GD350-7R5G-4	GDL-ACL0025-4CU	GDL-OCL0020-4CU	
	GD350-011G-4	GDL-ACL0035-4AL	GDL-OCL0025-4CU	
	GD350-015G-4	GDL-ACL0040-4AL	GDL-OCL0035-4AL	
	GD350-018G-4	GDL-ACL0051-4AL	GDL-OCL0040-4AL	
	GD350-022G-4	GDL-ACL0051-4AL	GDL-OCL0050-4AL	
	GD350-030G-4	GDL-ACL0070-4AL	GDL-OCL0060-4AL	
	GD350-037G-4	GDL-ACL0090-4AL	GDL-OCL0075-4AL	
	GD350-045G-4	GDL-ACL0110-4AL	GDL-OCL0092-4AL	
	GD350-055G-4	GDL-ACL0150-4AL	GDL-OCL0115-4AL	
	GD350-075G-4	GDL-ACL0150-4AL	GDL-OCL0150-4AL	
	GD350-090G-4	GDL-ACL0220-4AL	GDL-OCL0220-4AL	
	GD350-110G-4	GDL-ACL0220-4AL	GDL-OCL0220-4AL	
	GD350-132G-4	GDL-ACL0265-4AL	GDL-DCL0300-4AL	GDL-OCL0265-4AL

	Model	Input reactor	DC reactor	Output reactor
380V	GD350-160G-4	GDL-ACL0330-4AL	GDL-DCL0365-4AL	GDL-OCL0330-4AL
	GD350-185G-4	GDL-ACL0390-4AL	GDL-DCL0455-4AL	GDL-OCL0400-4AL
	GD350-200G-4	GDL-ACL0390-4AL	GDL-DCL0455-4AL	GDL-OCL0400-4AL
	GD350-220G-4	GDL-ACL0450-4AL	GDL-DCL0505-4AL	GDL-OCL0450-4AL
	GD350-250G-4	GDL-ACL0500-4AL	GDL-DCL0550-4AL	GDL-OCL0500-4AL
	GD350-280G-4	GDL-ACL0500-4AL	GDL-DCL0675-4AL	GDL-OCL0560-4AL
	GD350-315G-4	GDL-ACL0580-4AL	GDL-DCL0675-4AL	GDL-OCL0660-4AL
	GD350-355G-4	Standard Built-in	GDL-DCL0810-4AL	GDL-OCL0660-4AL
	GD350-400G-4		GDL-DCL0810-4AL	GDL-OCL0720-4AL
	GD350-450G-4		GDL-DCL1000-4AL	GDL-OCL0820-4AL
	GD350-500G-4		GDL-DCL1000-4AL	GDL-OCL1000-4AL
660V	GD350-022G-6	GDL-ACL0045-6CU	GDL-DCL0045-6CU	GDL-OCL0045-6CU
	GD350-030G-6	GDL-ACL0045-6CU	GDL-DCL0050-6CU	GDL-OCL0045-6CU
	GD350-370G-6	GDL-ACL0050-6CU	GDL-DCL0080-6CU	GDL-OCL0045-6CU
	GD350-045G-6	GDL-ACL0060-6CU	GDL-DCL0080-6CU	GDL-OCL0060-6CU
	GD350-055G-6	GDL-ACL0090-6CU	GDL-DCL0080-6CU	GDL-OCL0090-6CU
	GD350-075G-6	GDL-ACL0090-6CU	GDL-DCL0165-6CU	GDL-OCL0090-6CU
	GD350-090G-6	GDL-ACL0110-6CU	GDL-DCL0165-6CU	GDL-OCL0110-6CU
	GD350-110G-6	GDL-ACL0150-6CU	GDL-DCL0165-6CU	GDL-OCL0150-6CU
	GD350-132G-6	GDL-ACL0150-6CU	GDL-DCL0265-6CU	GDL-OCL0150-6CU
	GD350-160G-6	GDL-ACL0200-6CU	GDL-DCL0265-6CU	GDL-OCL0200-6CU
	GD350-185G-6	GDL-ACL0200-6CU	GDL-DCL0265-6CU	GDL-OCL0200-6CU
	GD350-200G-6	GDL-ACL0250-6CU	GDL-DCL0330-6CU	GDL-OCL0250-6CU
	GD350-220G-6	GDL-ACL0250-6CU	GDL-DCL0330-6CU	GDL-OCL0250-6CU
	GD350-250G-6	GDL-ACL0300-6CU	GDL-DCL0330-6CU	GDL-OCL0300-6CU
	GD350-280G-6	GDL-ACL0300-6CU	GDL-DCL0475-6CU	GDL-OCL0300-6CU
	GD350-315G-6	GDL-ACL0400-6CU	GDL-DCL0475-6CU	GDL-OCL0400-6CU
	GD350-355G-6	GDL-ACL0400-6CU	GDL-DCL0475-6CU	GDL-OCL0400-6CU
	GD350-400G-6	Standard Built-in	GDL-DCL0600-6CU	GDL-OCL0480-6CU
	GD350-450G-6		GDL-DCL0600-6CU	GDL-OCL0480-6CU
	GD350-500G-6		GDL-DCL0750-6CU	GDL-OCL0600-6CU
	GD350-560G-6		GDL-DCL0750-6CU	GDL-OCL0600-6CU
GD350-630G-6	GDL-DCL0805-6CU		GDL-OCL0800-6CU	

- Above options are external installation, customer need to specify them when choosing and purchasing.
- Can be flexibly adjusted according to the rated working current value.
- For reactors selection with different material requirements from the above recommended table, please refer to 《Low Voltage VFD GDL Series Filter Option Brochure》.

Filters

FLT-P 04 045 L-B

A B C D E F

Filter identifier	Field description
A	FLT: Name of the VFD filter series
B	Filter type P: Power input filter L: Output filter
C	Voltage class 04: AC 3PH 380V (-15%)-440V (+10%) 06: AC 3PH 520V (-15%)-690V (+10%)
D	3-digit code indicating the rated current. For example, 015 indicates 15A.
E	Filter performance L: General H: High-performance
F	Filter application environment A: Environment Category I, C1 (EN 61800 -3:2004) B: Environment Category I, C2 (EN 61800 -3:2004) C: Environment Category II, C3 (EN61800 -3:2004)

VFD model	Input filter	Output filter
AC 3PH 380V (-15%)-440V (+10%)		
GD350-1R5G-4	FLT-P04006L-B	FLT-P04006L-B
GD350-2R2G-4		
GD350-004G-4	FLT-P04016L-B	FLT-P04016L-B
GD350-5R5G-4		
GD350-7R5G-4	FLT-P04032L-B	FLT-P04032L-B
GD350-011G-4		
GD350-015G-4	FLT-P04045L-B	FLT-P04045L-B
GD350-018G-4		
GD350-022G-4	FLT-P04065L-B	FLT-P04065L-B
GD350-030G-4		
GD350-037G-4	FLT-P04100L-B	FLT-P04100L-B
GD350-045G-4		
GD350-055G-4	FLT-P04150L-B	FLT-P04150L-B
GD350-075G-4		
GD350-090G-4	FLT-P04240L-B	FLT-P04240L-B
GD350-110G-4		
GD350-132G-4	FLT-P04400L-B	FLT-P04400L-B
GD350-160G-4		
GD350-185G-4		
GD350-200G-4		

VFD model	Input filter	Output filter
AC 3PH 380V (-15%)–440V (+10%)		
GD350-220G-4	FLT-P04600L-B	FLT-P04600L-B
GD350-250G-4		
GD350-280G-4		
GD350-315G-4	FLT-P04800L-B	FLT-P04800L-B
GD350-355G-4		
GD350-400G-4		
GD350-450G-4	FLT-P041000L-B	FLT-P041000L-B
GD350-500G-4		
AC 3PH 520V (-15%)–690V (+10%)		
GD350-022G-6	FLT-P06050H-B	FLT-P06050H-B
GD350-030G-6		
GD350-370G-6		
GD350-045G-6	FLT-P06100H-B	FLT-P06100H-B
GD350-055G-6		
GD350-075G-6		
GD350-090G-6		
GD350-110G-6	FLT-P06200H-B	FLT-P06200H-B
GD350-132G-6		
GD350-160G-6		
GD350-185G-6		
GD350-200G-6	FLT-P06300H-B	FLT-P06300H-B
GD350-220G-6		
GD350-250G-6		
GD350-280G-6		
GD350-315G-6	FLT-P06400H-B	FLT-P06400H-B
GD350-355G-6		
GD350-400G-6	FLT-P061000H-B	FLT-P061000H-B
GD350-450G-6		
GD350-500G-6		
GD350-560G-6		
GD350-630G-6		

Brake system

VFD model	Brake unit model	Resistance applicable for brake torque (Ω)	Dissipated power of brake resistor (kW)			Min. allowable brake resistor (Ω)
			10% brake usage	50% brake usage	80% brake usage	
AC 3PH 380V (-15%)-440V (+10%)						
GD350-1R5G-4	Standard Built-in	326	0.23	1.1	1.8	170
GD350-2R2G-4		222	0.33	1.7	2.6	130
GD350-004G-4		122	0.6	3	4.8	80
GD350-5R5G-4		89	0.75	4.1	6.6	60
GD350-7R5G-4		65	1.1	5.6	9	47
GD350-011G-4		44	1.7	8.3	13.2	31
GD350-015G-4		32	2	11	18	23
GD350-018G-4		27	3	14	22	19
GD350-022G-4		22	3	17	26	17
GD350-030G-4		17	5	23	36	17
GD350-037G-4		13	6	28	44	11.7
GD350-045G-4		Optional Built-in	10	7	34	54
GD350-055G-4	8		8	41	66	
GD350-075G-4	6.5		11	56	90	
GD350-090G-4	5.4		14	68	108	4.4
GD350-110G-4	4.5		17	83	132	
GD350-132G-4	DBU100H-220-4	3.7	20	99	158	3.2
GD350-160G-4	DBU100H-320-4	3.1	24	120	192	2.2
GD350-185G-4		2.8	28	139	222	
GD350-200G-4		2.5	30	150	240	
GD350-220G-4	DBU100H-400-4	2.2	33	165	264	1.8
GD350-250G-4		2.0	38	188	300	
GD350-280G-4	Two sets	3.6*2	21*1	105*2	168*2	2.2*2
GD350-315G-4		3.2*2	24*2	118*2	189*2	
GD350-355G-4	DBU100H-320-4	2.8*2	27*2	132*2	210*2	
GD350-400G-4	2.4*2	30*2	150*2	240*2		
GD350-450G-4	Two sets	2.2*2	34*2	168*2	270*2	
GD350-500G-4	DBU100H-400-4	2.0*2	38*2	186*2	300*2	1.8*2

VFD model	Brake unit model	Resistance applicable for brake torque (Ω)	Dissipated power of brake resistor (kW)			Min. allowable brake resistor (Ω)
			10% brake usage	50% brake usage	80% brake usage	
AC 3PH 520V (-15%)~690V (+10%)						
GD350-022G-6	DBU100H-110-6	55	4	17	27	10.0
GD350-030G-6		40.3	5	23	36	
GD350-370G-6		32.7	6	28	44	
GD350-045G-6		26.9	7	34	54	
GD350-055G-6		22.0	8	41	66	
GD350-075G-6		16.1	11	56	90	
GD350-090G-6		13.4	14	68	108	
GD350-110G-6		11.0	17	83	132	
GD350-132G-6	DBU100H-160-6	9.2	20	99	158	6.9
GD350-160G-6		7.6	24	120	192	
GD350-185G-6	DBU100H-220-6	6.5	28	139	222	5.0
GD350-200G-6		6.1	30	150	240	
GD350-220G-6		5.5	33	165	264	
GD350-250G-6	DBU100H-320-6	4.8	38	188	300	3.4
GD350-280G-6		4.3	42	210	336	
GD350-315G-6		3.8	47	236	378	
GD350-355G-6		3.5	53	263	420	
GD350-400G-6	DBU100H-400-6	3.0	60	300	480	2.8
GD350-450G-6	Two sets	5.5*2	34*2	168*2	270*2	3.4*2
GD350-500G-6		4.8*2	38*2	188*2	300*2	
GD350-560G-6	DBU100H-320-6	4.3*2	42*2	210*2	336*2	
GD350-630G-6		3.8*2	47*2	236*2	378*2	

Extension cards



IO extension card1
EC-IO501-00



IO expansion card 2
EC-IO502-00



Programmable extension card
EC-PC502-00



Bluetooth/WIFI communication card
EC-TX501/EC-TX502



PROFIBUS-DP communication card
EC-TX503D



CAN multi-protocol communication card
EC-TX505C



PROFINET communication card
EC-TX509C



Ethernet multi-protocol communication card
EC-TX510B



EtherCAT communication card
EC-TX508



Sin/Cos PG card
EC-PG502



UWV incremental PG card
EC-PG503-05



Resolver PG card
EC-PG504-00



Multifunction incremental PG card
EC-PG505-12



24V incremental PG card
EC-PG505-24B



Simplified incremental PG card
EC-PG507-12



24V simplified incremental PG card
EC-PG507-24



SSI absolute value PG card
EC-PG508-05



GPRS card
EC-IC501-2



4G card
EC-IC502-2-CN
EC-IC502-2-EU
EC-IC502-2-LA



24V power supply card
EC-PS501-24

Name	Model	Specification
IO extension card 1	EC-IO501-00	4 digital inputs 1 digital output 1 analog input 1 analog output 2 relay outputs: 1 double-contact output, and 1 single-contact output
IO extension card 2	EC-IO502-00	4 digital inputs 1 PT100 1 PT1000 2 relay outputs: single-contact output
Programmable expansion card	EC-PC502-00	<ul style="list-style-type: none"> Adopting the global mainstream development environment PLC, supporting multiple types of programming languages, such as the instruction language, structural text, function block diagram, ladder diagram, continuous function chart, and sequential function chart Supporting breakpoint commissioning and periodic task run mode selection Providing user program storage space of 16K steps, and data storage space of 8K words 6 digital inputs • 2 relay outputs • 1 AI and 1 AO 1RS485 communication channel, supporting the host controller to switch the master/slave Saving data of 1K words at power down
PROFIBUS-DP communication card	EC-TX503D	Supporting the PROFIBUS-DP protocol
CAN multi-protocol communication card	EC-TX505C	<ul style="list-style-type: none"> Based on the CAN2.0A and CAN2.0B physical layer Supporting the CANopen protocol • Adopting INVT's master-slave control proprietary protocol
PROFINET communication card	EC-TX509C	Supporting the PROFINET protocol
Ethernet multi-protocol communication card	EC-TX510B	<ul style="list-style-type: none"> Supporting the Ethernet IP protocol and ODVA protocol With two Ethernet IP ports, supporting 10/100M half/full duplex operating Supporting star, line, and ring network topologies (but not supporting ring network monitoring)
EtherCAT communication card	EC-TX508	Supporting EtherCAT protocol
Sin/Cos PG card	EC-PG502	<ul style="list-style-type: none"> Applicable to Sin/Cos encoders with or without CD signals Supporting A, B, Z frequency-divided output • Supporting input of pulse train reference
UVW incremental PG card	EC-PG503-05	<ul style="list-style-type: none"> Applicable to 5V differential encoders • Supporting A, B, Z orthogonal input Supporting U, V, W 3PH pulse input • Supporting A, B, Z frequency-divided output Supporting input of pulse train reference
Resolver PG card	EC-PG504-00	<ul style="list-style-type: none"> Applicable to resolver encoders • Supporting simulated A, B, Z frequency-divided output of resolvers Supporting input of pulse train reference
Multi-function incremental PG card	EC-PG505-12	<ul style="list-style-type: none"> Applicable to OC encoders of 5 V or 12 V • Applicable to push-pull encoders of 5 V or 12 V Applicable to differential encoders of 5 V • Supporting the orthogonal input of A, B, and Z Supporting the frequency-divided output of A, B, and Z • Supporting pulse train setting
24V incremental PG card	EC-PG505-24B	<ul style="list-style-type: none"> Applicable to 24V OC encoders • Applicable to 24 V push-pull encoders Supporting A, B, Z orthogonal input • Supporting A, B, Z frequency-divided output Supporting pulse train reference input
SSI absolute value PG card	EC-PG508-05	Suitable for communication absolute value encoder
Simple incremental PG card	EC-PG507-12	<ul style="list-style-type: none"> Applicable to 5 V or 12 V OC encoders • Applicable to 5 V or 12 V push-pull encoders Applicable to 5 V differential encoders
24V power supply card	EC-PS501-24	<ul style="list-style-type: none"> Input voltage range: DC18~30V (rated 24Vdc) / 2A; Output voltage 3: +5V/1A (±5%)、+15V/0.2A (±10%)、-15V/0.2A (±10%)
Bluetooth communication card	EC-TX501-1 EC-TX501-2	<ul style="list-style-type: none"> Supporting Bluetooth 4.0 With INVT's mobile phone APP, you can set the parameters and monitor the states of the VFD through Bluetooth The maximum communication distance in open environments is 30 m EC-TX501-1 is equipped with a built-in antenna and applicable to molded case machines EC-TX501-2 is configured with an external sucker antenna and applicable to sheet metal machines
WIFI communication card	EC-TX502-1 EC-TX502-2	<ul style="list-style-type: none"> Meeting IEEE802.11b/g/n With INVT's mobile phone APP, you can monitor the VFD locally or remotely through WIFI communication The maximum communication distance in open environments is 30 m EC-TX501-1 is equipped with a built-in antenna and applicable to molded case machines EC-TX501-2 is configured with an external sucker antenna and applicable to sheet metal machines
GPRS card	EC-IC501-2	<ul style="list-style-type: none"> Supporting IoT monitoring Supporting remote VFD upgrade
4G card	EC-IC502-2-CN EC-IC502-2-EU EC-IC502-2-LA	<ul style="list-style-type: none"> Supporting standard RS485 interfaces Supporting 4G communication

Marketing service network

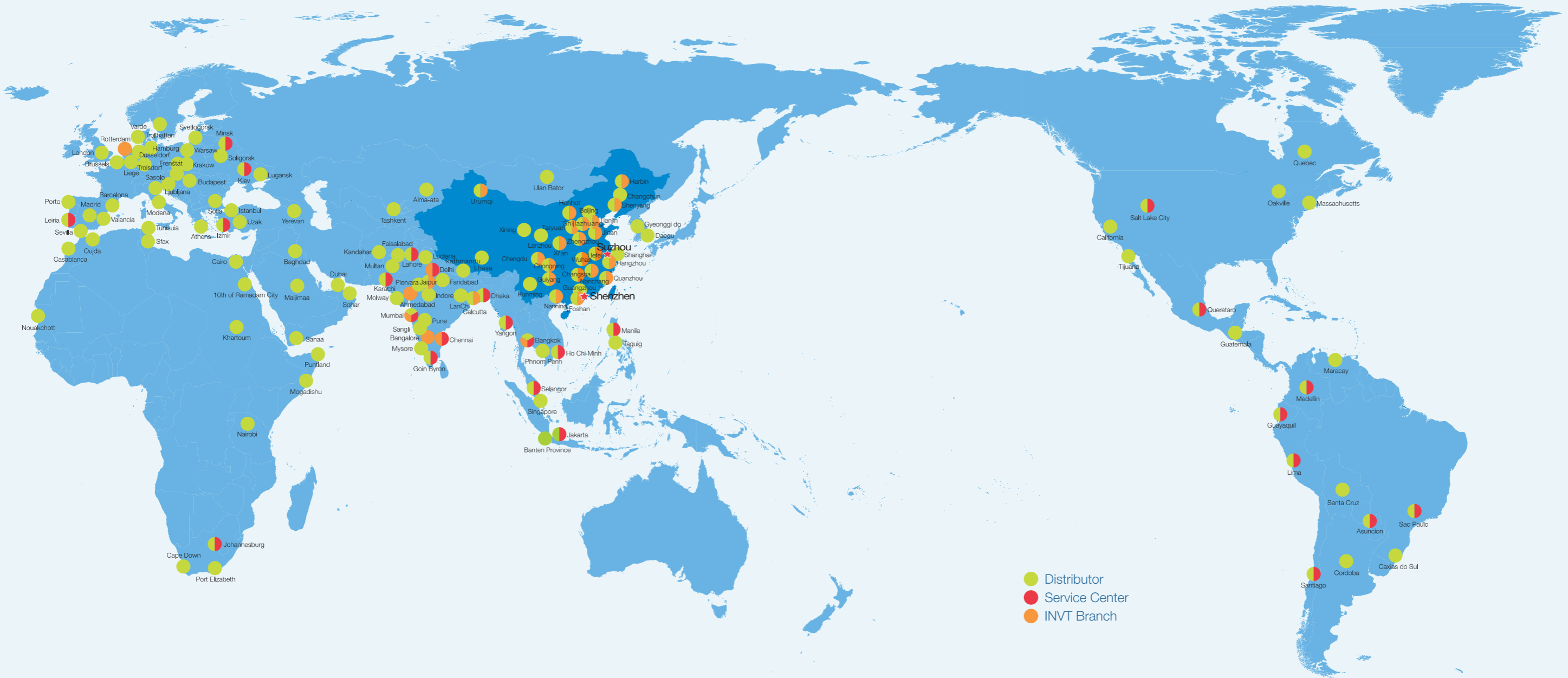

Your trusted industry automation solution provider

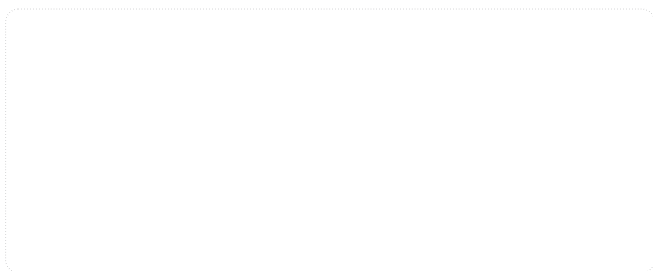

E-mail: overseas@invt.com.cn Website: www.invt.com

SHENZHEN INVT ELECTRIC CO.,LTD. INVT Guangming Technology Building, Songbai Road, Matian, Guangming District, Shenzhen, China

Industrial Automation: • HMI • PLC • VFD • Servo System • Elevator Intelligent Control System
• Rail Transit Traction System

Electric Power: • UPS • DCIM • Solar Inverter • New Energy Vehicle Powertrain System
• New Energy Vehicle Charging System • New Energy Vehicle Motor

INVT Copyright.
Information may be subject to change without notice during product improving.

66003-00162 202407(V3.0)